

MWC[™]
GSMA

SHANGHAI
26-28 JUNE 2024

MWC24

FUTURE FIRST

Partner Programmes

Theatre Package

Grand Shanghai Ballroom 1

Kerry Hotel

Welcome

Welcome to Partner Programmes at MWC Shanghai 2024.

The GSMA Event Programme Management Team is committed to working with you to make your event a success. As such, we have outlined guidelines as to how our teams will work together.

Partnership Commitment

- GSMA will communicate with you during normal working hours by email, telephone, or Microsoft Teams. Other communication channels, such as WeChat and WhatsApp, will not be used for project discussions and decisions.
- GSMA will always try to respond to you promptly during normal working hours. However, communications received outside of these hours may not receive a reply until the next working day.
- Partner staff, GSMA staff, contractors and suppliers will treat each other with mutual respect and understanding.
- GSMA will promptly follow timings for rehearsals and walk throughs. Due to subsequent bookings of the space, extensions are not possible, and all parties must vacate the space as soon as their scheduled timing is over.
- Any changes to the arrangement of furniture and other elements, or the addition of new elements, must first be discussed and agreed with GSMA.
- Professional conduct is expected by all parties, always.

We look forward to working with you over the coming weeks and bringing your session vision to fruition.

Kind regards.

MWC[™]
GSMA

上海
2024年6月26 - 28 日

Operations

Venue Overview

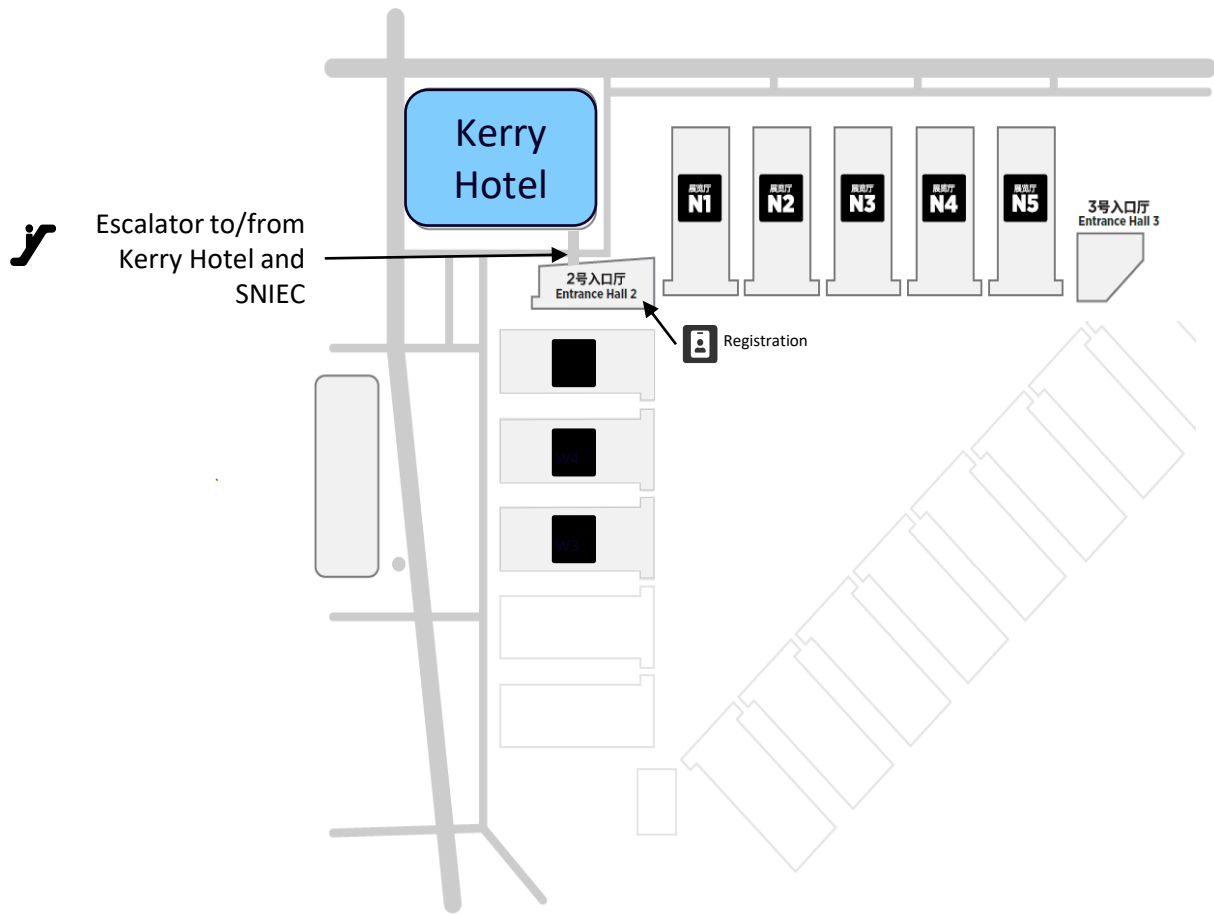

KERRY HOTEL – LEVEL 3

Grand Shanghai Ballroom 1

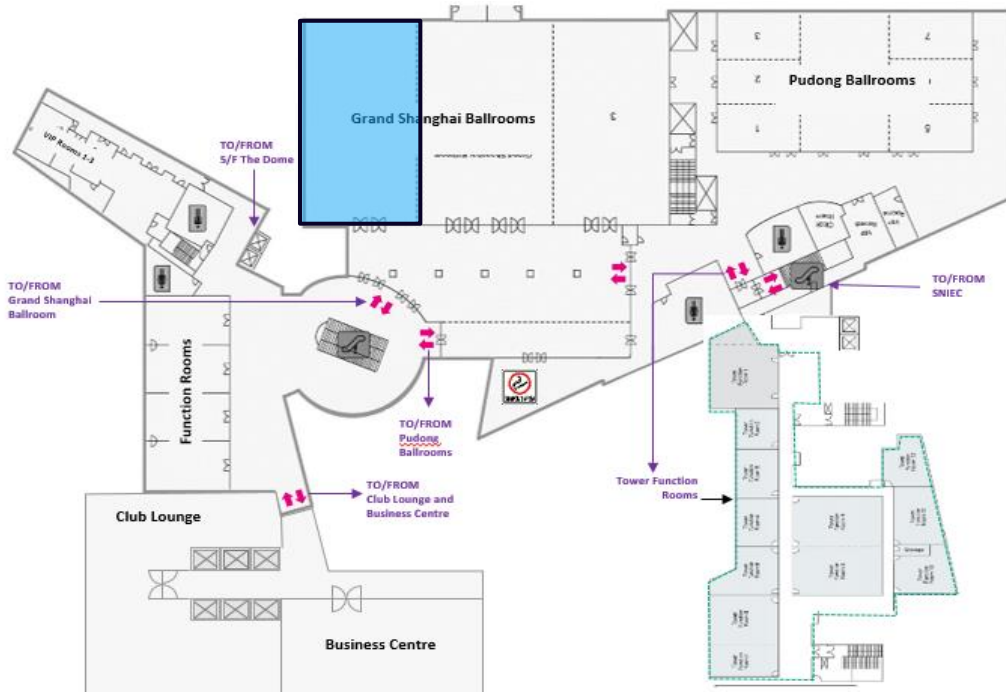

General Package

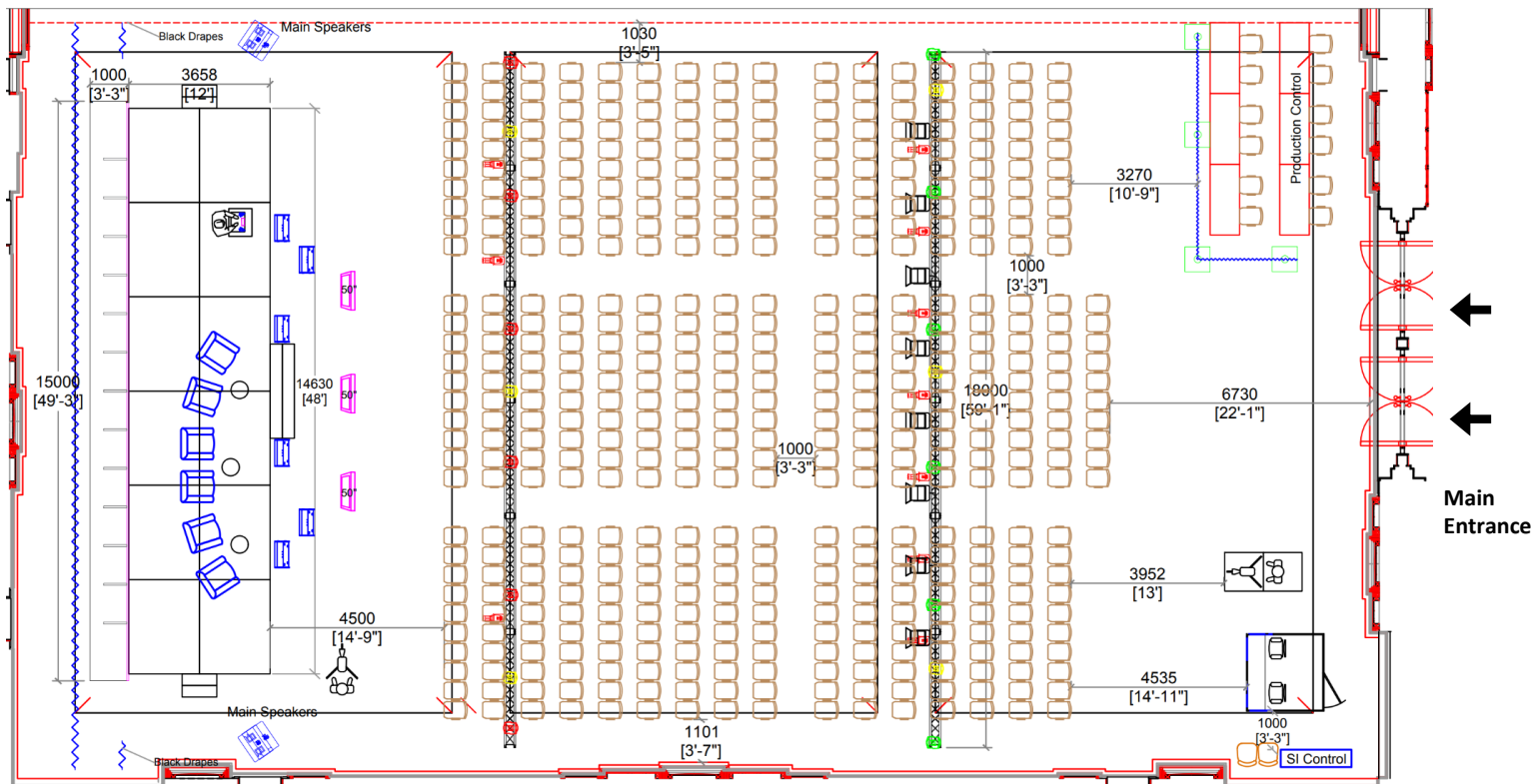

AUDITORIUM

- Theatre style set up for 490 attendees
- LED on stage
- Lectern with wired microphone for speaker
- Standard AV package including technicians
- Sofa seating with 3 coffee tables and 6 single-seater armchairs on stage if needed
- Bottled water for speakers and attendees
- Coffee Break (Cookies with coffee and tea) for 490 attendees

FOYER

- Client branding opportunity – LED Registration Backdrop 4m x 3mW
- Standard registration table with black cloth

GENERAL

- 4 scanning support staff plus 2 general event support staff
- Option to distribute giveaways (printed materials, gifts or collateral) - client responsible for production and delivery costs

AV Package

AUDITORIUM EQUIPMENT - VIDEO

VIDEO - MAIN PROJECTION

3.9mm LED Wall , L15m x H4.5m

VIDEO - COMFORT MONITORS ON STAGE

3 x 50" LCD Monitor on Floor Angled Stands

VIDEO – CONTROL SYSTEM

1 x Ascender 3204 with Expander & Outboard Gears
1 x Analogway Shotbox Live Core Pre Set Controller
1 x Barco Folsom Image Pro HD Image Scaler & Processor
1 x Barco Folsom DVI Matrix Pro 8x8 For Source Splitter
1 x Barco Folsom HDSI Matrix Pro 8x8 For Source Splitter

VIDEO – PLAYBACK & PRESENTATION

2 x MacBook Pro with PVP Player
3 x Lenovo Laptop
1 x D'san Countdown Timer
1 x Perfect Cue Wireless Clicker System

VIDEO – CAMERA SYSTEM

2 x Sony Professional Camera
2 x Tripod Stand
1 x Panasonic HS-410 Camera Vision Mixer
3 x BM Hyperdeck Studio Pro HD Recorder (MP4. file)
2 x BM Dual Preview Monitor

VIDEO - ACCESSORIES

1 x Wiring and accessories

AUDITORIUM EQUIPMENT - SOUND

SOUND - SYSTEM P.A.

6 x Logic Line Array System with Subs on Floor
Cabling As Needed

SOUND – FRONTFILL/MONITOR

4 x Speaker Stands
Cabling As Needed

SOUND - CONTROL FOH

1 x Wiring and accessories
1 x YAMAHA M7CL 48 Channel Audio Mixer
1 x Audio Distribution Amplifier
1 x MP3 Audio Recorder
2 x Interspace Laptop DI

SOUND - MICROPHONES

1 x Wiring and accessories
2 x Podium Mics

SOUND - MICROPHONES R.F.

8 x Shure Wireless Lapel
4 x Shure Wireless Handheld with stands
12 x Channels Wireless Microphone Receiver

SOUND – INTERCOM FOR PRODUCTION CREW

1 x Wiring and accessories
4 x Wired Belt pack And Headset
1 x Intercom Wireless Base
4 x Belt pack Intercom Wireless

SOUND - POWER AND SIGNAL

1 x Wiring and accessories

AV Package

AUDITORIUM EQUIPMENT - LIGHTING

LIGHTING - STRUCTURE AND RIGGING

Estimated Truss For Lighting

LIGHTING - FIXTURES

6 x ETC Source 4

8 x Selecon Rama

8 x Terbly Beam Moving Light

6 x Spot One Wash Moving Light

6 x Spot LED Effect Moving Light

1 x LED Profile Light for Custom Gobo

LIGHTING - CONTROL

1 x Avolite Tiger Touch

1 x Dimmer Rack As Needed

LIGHTING - SIGNAL AND POWER

1 Wiring and accessories

FOYER EQUIPMENT

VIDEO

3.9mm LED Wall with base (L4m x H3m)

Accessories as needed

Laptop for LED Wall image

STAGE SET

PLATFORM WITH BLACK FABRIC SKIRTING

L30ft x W16ft x H2ft

VIDEO – MAIN PROJECTION

3.9mm LED Wall , L15m x H4.5m

AV CREW

Show Caller

Responsible for executing the cues for the event with the operators in the room. Will be on intercoms with all the main operators.

Please note: *The show caller functions do not include stage management. A stage manager must be provided by the client if needed.*

Video Graphic Operator

Responsible for managing presentations and graphics.

Video Technician

Set up, management, operation of equipment.

Sound FOH Operator

Operates mixing desk. Responsible for the different audio feeds requested and anything related to live audio in the room.

Sound Technician

Set up, management and operation of wireless equipment, mics and intercom.

Lighting FOH Operator

Operates Lighting desk.

If you require additional AV equipment, please submit your enquires to your dedicated operations manager.

ORDER DEADLINE: 10 June 2024

Please note that any equipment request may take 2 to 3 days to be quoted. All requests are subject to availability. Late order surcharges and cancellation fees apply..

Stage Set Technical Plan

Side Elevation

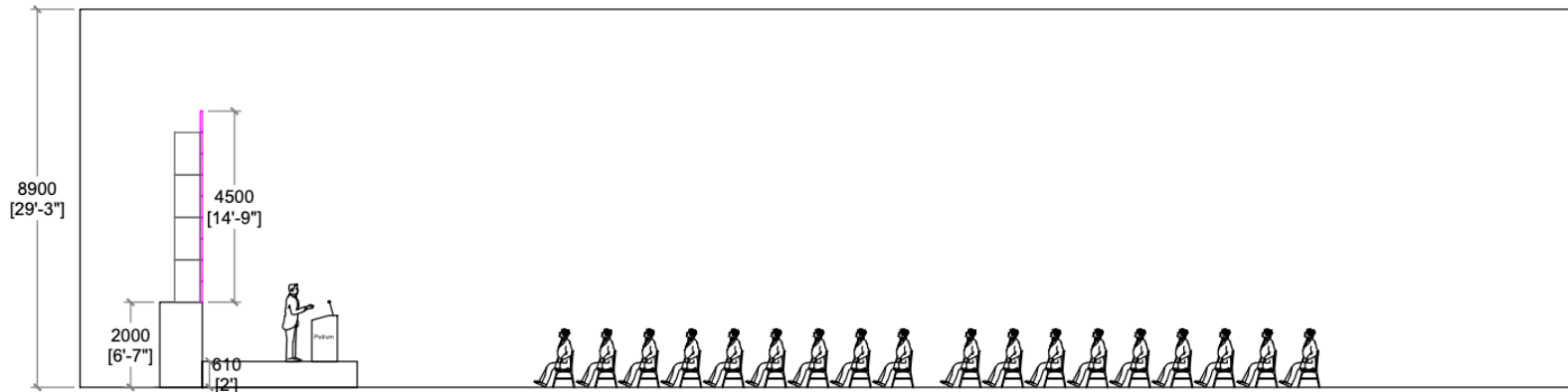

Front Elevation

CHANDELIER

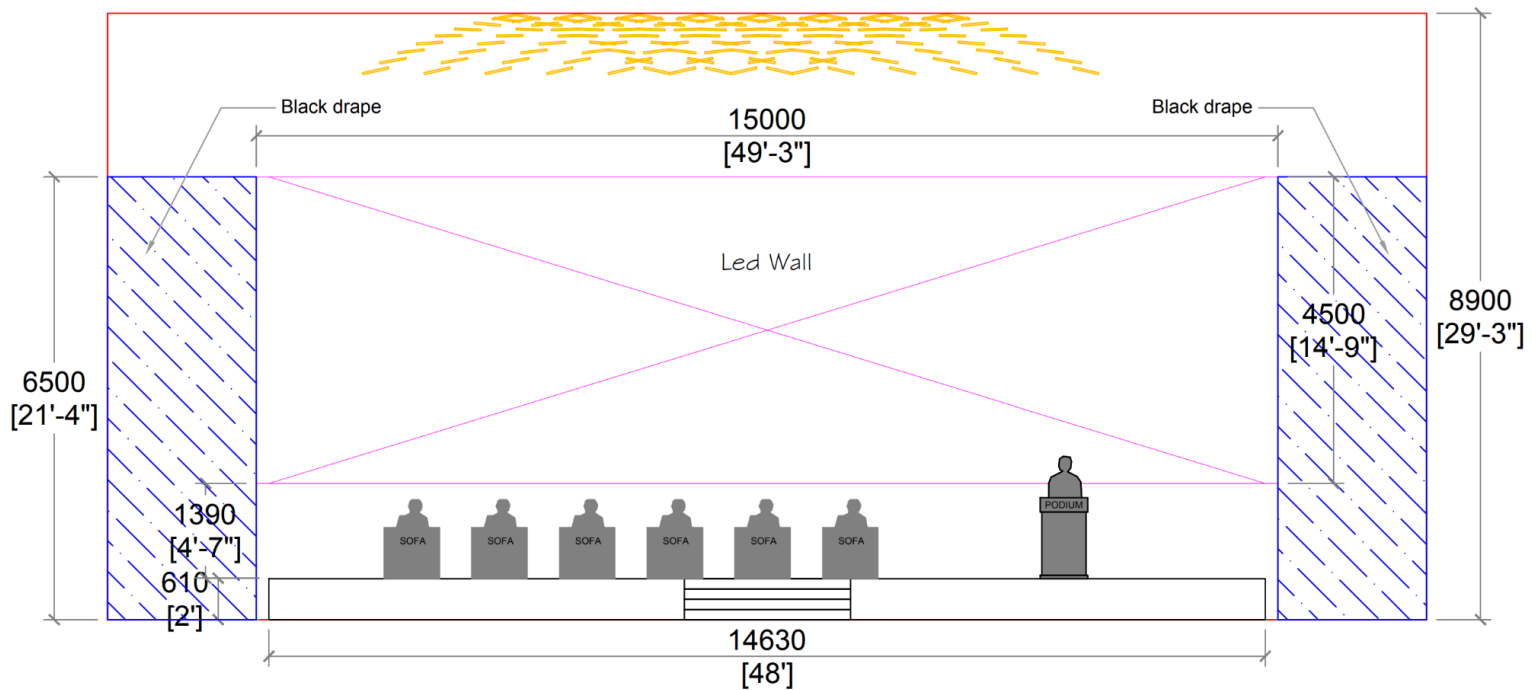

LED Resolutions

GRAND SHANGHAI BALLROOM 1

- Resolution indicated below are in reference to the actual size for the LED wall.
- 16:9 content can be 1920x1080px and 4:3 content can be 1024x768px (or higher).
- Video files to be in .MOV (H264) or .MP4 format.
- Still graphics to be in high-res .JPG format.

For full-screen content, eg. background graphic, full-screen presentation or video

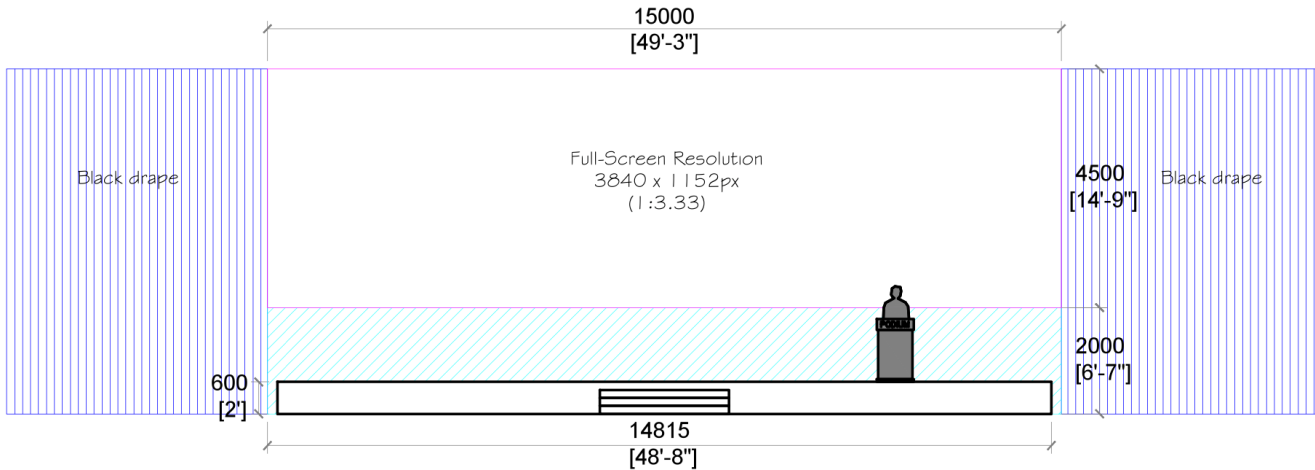

For 1 x PIP in centre (for PPT or Video etc. in 16:9 aspect ratio)

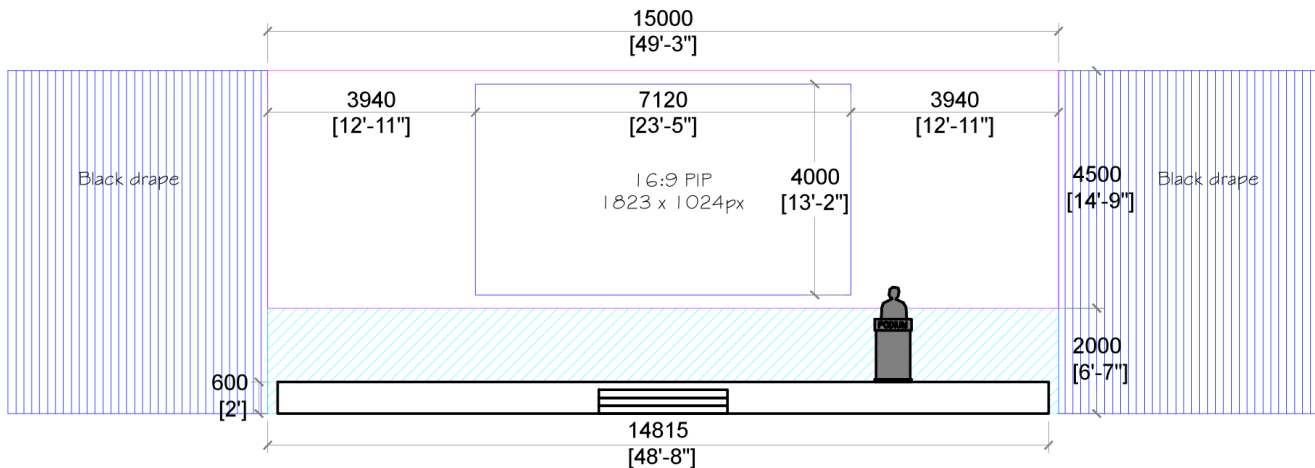

For 1 x PIP in centre (for PPT or Video etc. in 4:3 aspect ratio)

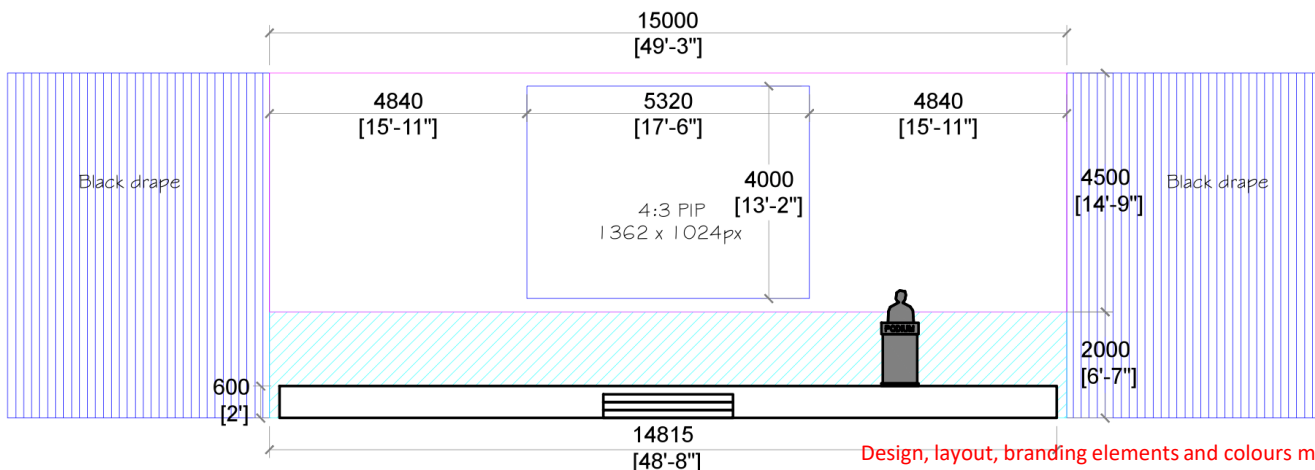

Design, layout, branding elements and colours may change.

LED Resolutions

For 1 x PIP at side (for PPT, Video or IMAG etc. in 16:9 aspect ratio)

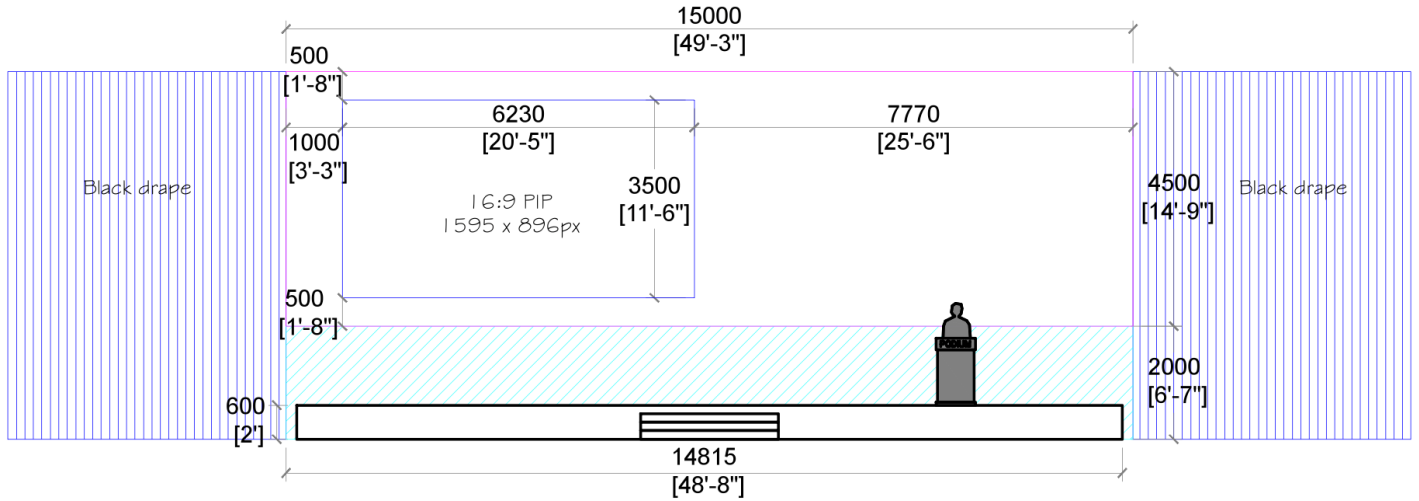

For 1 x PIP at side (for PPT or Video etc. in 4:3 aspect ratio)

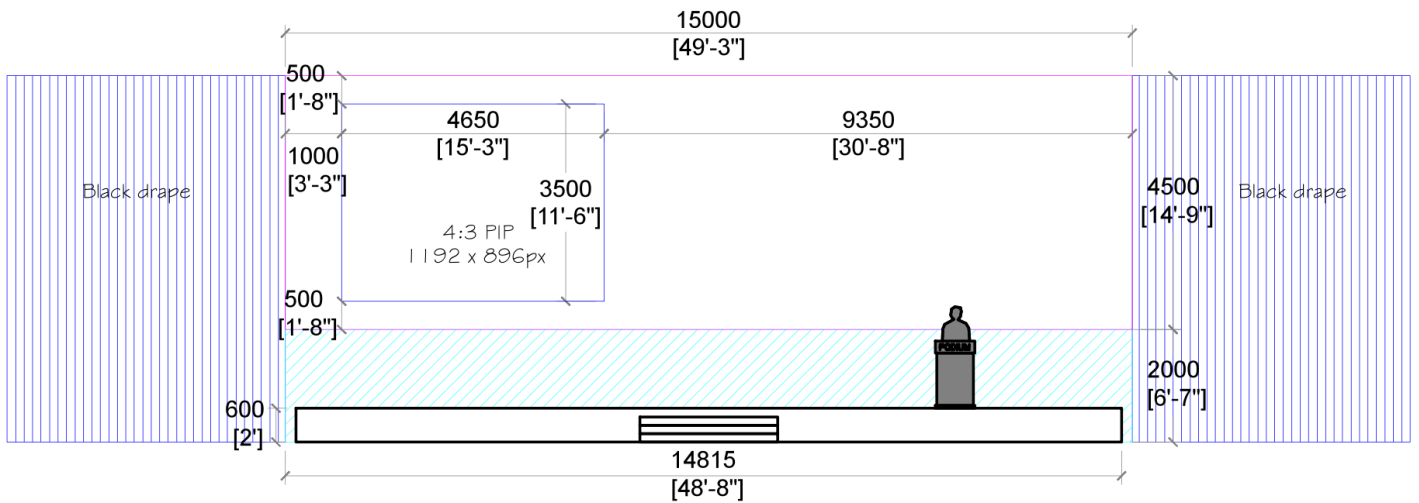

For 2 x PIP (for PPT, Video or IMAG etc. in 16:9 aspect ratio)

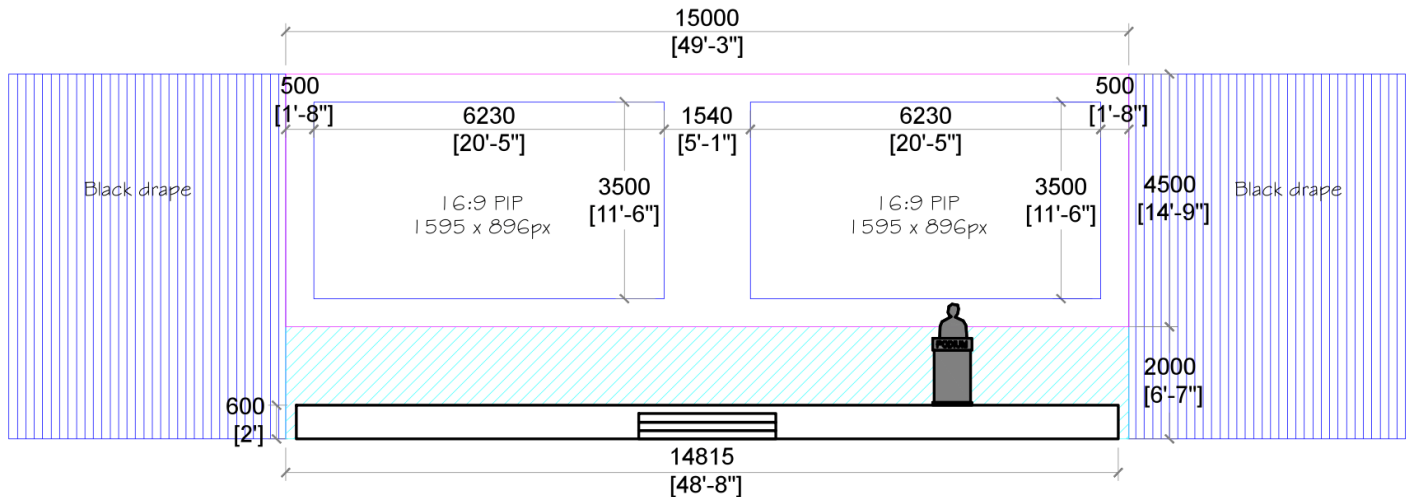

LED Resolutions

For 2 x PIP (for PPT or Video etc. in 4:3 aspect ratio)

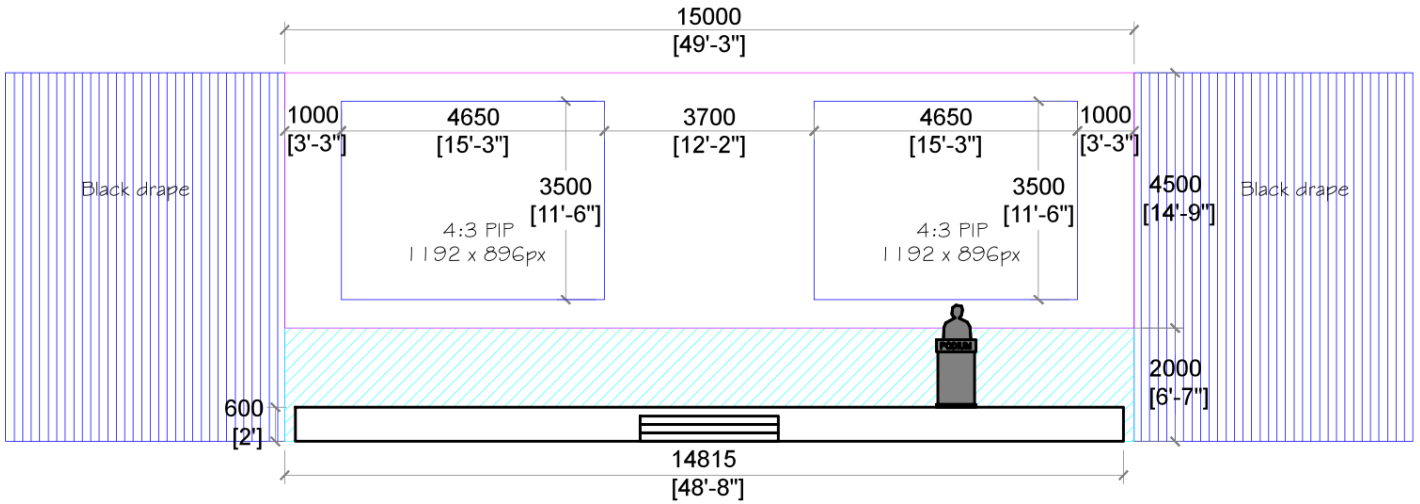

For 3 x PIP (for PPT, Video or IMAG etc. in 16:9 aspect ratio)

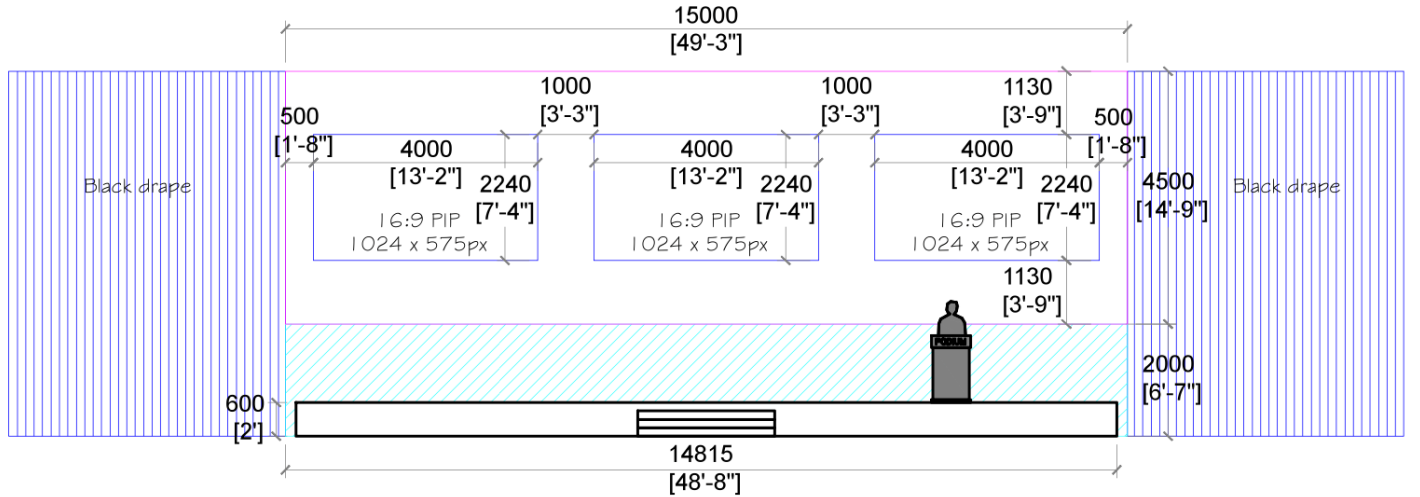

For 3 x PIP (for PPT or Video etc. in 4:3 aspect ratio)

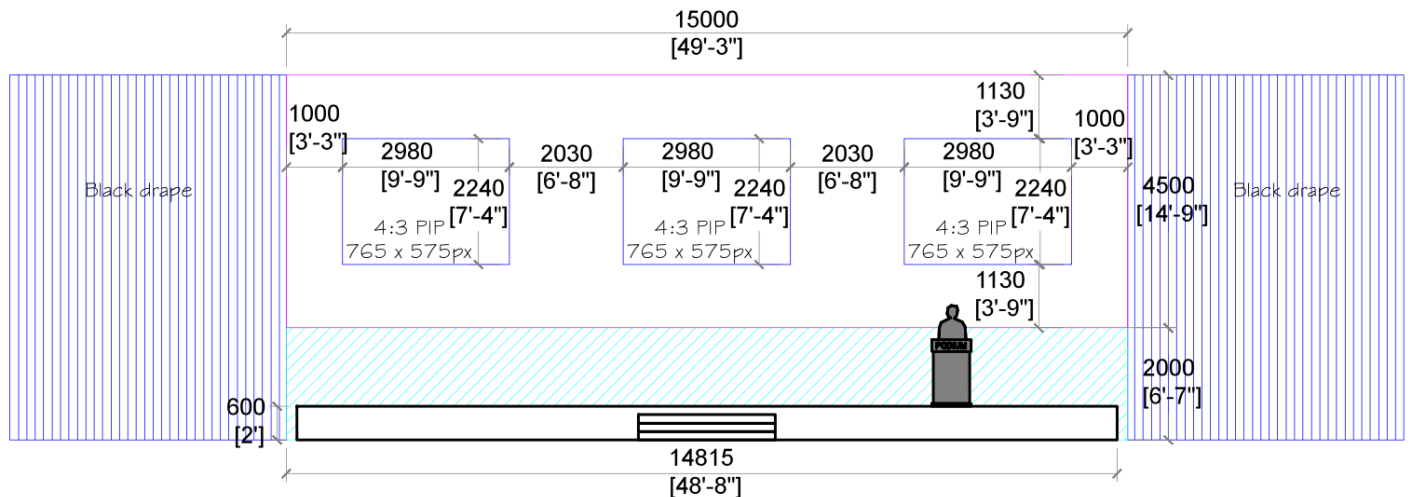

Branding Summary & Session Planning

Reference	Foyer	Size	Type	Format and file requirements	Submission Deadline
F1	Registration Backdrop	3.5m x 2m	Digital	Resolution (16:9): 1920 x 1080px Resolution (4:3): 1024 x 768px (or higher) Static image: hi-res .jpg Video: .MOV (H264) or .MP4 (NO SOUND) Full screen resolution (1:1.75): 896 x 512px	WEDNESDAY, 19 JUNE
Reference	Stage set	Size	Type	Format and file requirements	
S1	Main screen	15m x 4.5m	Digital	Resolution (16:9): 1920 x1080px Resolution (4:3): 1024 x 768px (or higher) Static image: hi-res .jpg Video: .MOV (H264) or .MP4 Presentations: - .ppt (Office 2019 or above) or Keynote - 16:9 - please also provide a copy as .pdf - please provide videos separately (not embedded in presentation)	WEDNESDAY, 19 JUNE
S2	Logo on lectern	700mm x 212mm	Printed	Vector file: .eps	MONDAY, 3 JUNE

SESSION PLANNING

It is compulsory to include appropriate **crew breaks** as part of your final agenda and event schedule.

Mandatory crew break timings as per below:

- 30 minutes – AM (morning) Break
- 60 minutes – Lunch Break
- 30 minutes – PM (afternoon) Break

For example: If you have a full day session from 09:00-17:00, your schedule may look like this:

- 09:15 – Event begins
- 09:15-10:15 – Keynote Presentations
- 10:15-10:45 – **AM (morning) break**
- 11:00 – Event resumes
- 11:00-12:00 – Panel Discussion
- 12:00-13:00 – **Lunch break**
- 13:30 – Event resumes
- 13:45-16:00 – Keynote Presentations
- 16:00-16:30 – **PM (afternoon) break**
- 17:00 – Event concludes

LED Registration Backdrop

Reference	Foyer	Size	Type	Format and file requirements	Submission Deadline
F1	Registration Backdrop	3.5m x 2m	Digital	Resolution (16:9): 1920 x 1080px Resolution (4:3): 1024 x 768px (or higher) Static image: hi-res .jpg Video: .MOV (H264) or .MP4 – No sound	WEDNESDAY, 19 JUNE
				Full screen resolution (1:1.75): 896 x 512px	

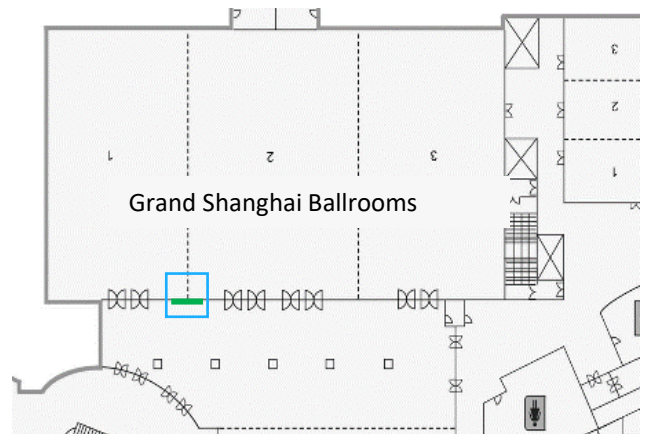
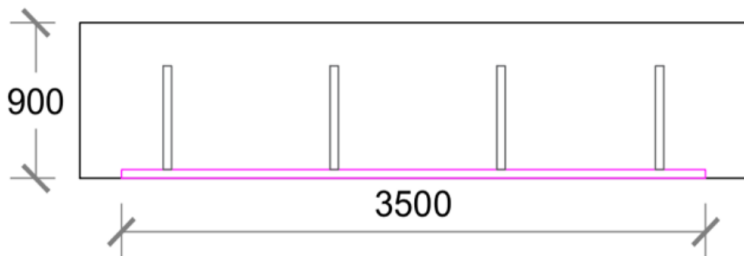
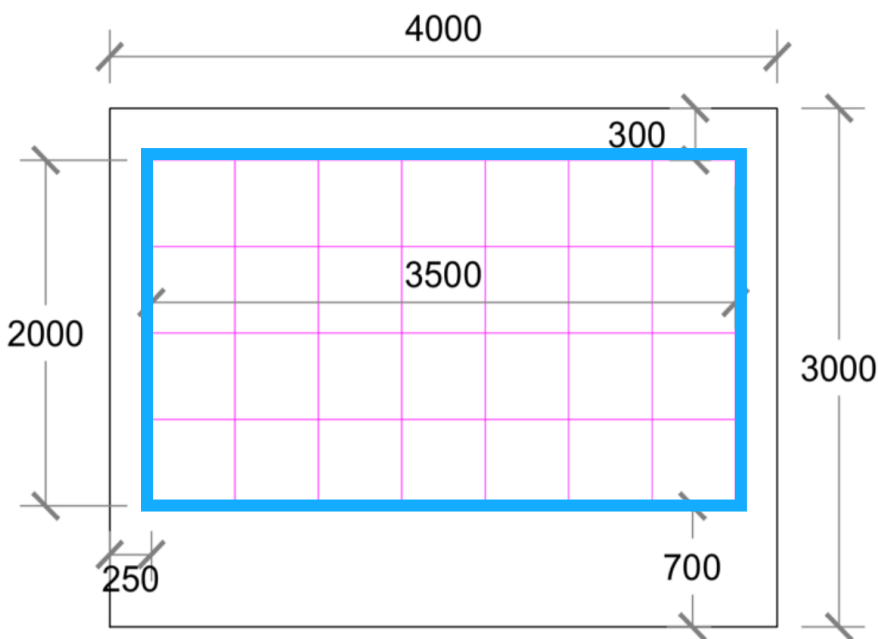

Furniture

STAGE



6 x Armchair
Size: 81cmW x 44cm Seat Height



3 x Table
Size: 110cmW x 55cmD x 45cmH

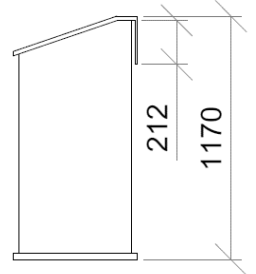
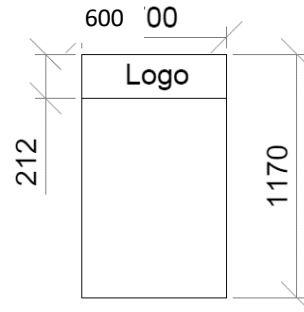

1 x Lectern
Size: 60cmW x 117cmH

AUDITORIUM



490 x Chair

FOYER

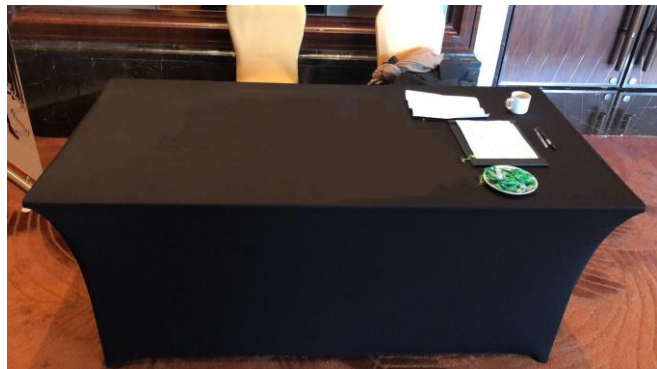

2 x Table
Size: 183cmW x 90cmD x 75cmH

Additional Orders

THE FOLLOWING SERVICES CAN BE ORDERED IN ADDITION TO THE STANDARD THEATRE PACKAGE:

HOSTESS

Should you require additional hostesses, please reach out directly to the Official Supplier and they will be able to provide you with a quote and full proposal. Once you have confirmed your requirements, you may proceed to book and pay directly with the Official Supplier

Contact details below:

Vivian Zhou

Email: vivian.zhou@link-event.com.cn

CATERING

Should you require additional catering, please reach out directly to the Official Supplier and they will be able to provide you with a quote and full proposal. Once you have confirmed your requirements, you may proceed to book and pay directly with the Official Supplier

Contact details below:

Yumi Liu

Email: yumi.liu@thekerryhotels.com

SIMULTANEOUS INTERPRETATION

Should you require Simultaneous Interpretation, please reach out directly to the Official Supplier and they will be able to provide you with a quote and full proposal. Once you have confirmed your requirements, you may proceed to book and pay directly with the Official Supplier

Contact details below:

Jo Lam

Email: jo@polyglot.com.hk

ADDITIONAL AV EQUIPMENT / IT FIXED LINES, ETC.

Should you require these additional services, you may reach out to your GSMA Operations Manager.

For IT requests, please ensure you provide information such as:

- How much additional bandwidth?
- For what purpose / usage?

Deadlines Operations

SERVICE	ORDER DEADLINE	LATE ORDERS & CANCELLATIONS
IT	17 May – Confirmation of services 3 June – Final deadline	
EVENT SUPPORT STAFF	31 May – Confirmation of services 12 June - Confirmation of final numbers & shift times	
CATERING	20 May - Confirmation of services 14 June - Confirmation of final numbers for food and beverage quantities	
AV – ADDITIONAL EQUIPMENT	10 June	Requests received after deadline are subject to availability and may incur surcharge.
AV – FILE SUBMISSION for Content (Main screen, Registration Backdrop, Run of Show)	19 June	
PRINTED SIGNAGE (Lectern artwork)	3 June	
SIMULTANEOUS INTERPRETATION	17 May – Confirmation of services 10 June - Confirmation of final numbers & shift times	

* Please note that a request for a quote may take 2-3 days to be processed. All quotes are subject to availability.

Terms and Conditions

ALL PACKAGES

- **Kerry Hotel has exclusivity** for ALL catering services in the Ballrooms. No other catering companies are permitted.
- Any complex build needs over and above the standard package provided are to be submitted to GSMA with sufficient time in order to approve the viability of the project – **6 weeks prior to the event**, clients or their appointed agency must submit:
 - A risk assessment (based on the client's specific design and event schedule);
 - A description and method statement (which includes floorplan, elevation and renders, AV, lighting, cabling and power specifications, as well as build and dismantle schedule); and
 - Duly evidenced event and liability insurance in respect of the specific requirements of the client's event ((i)-(iii) together, the "Mandatory Documents").

These will be reviewed by Operations and the Venue, for a feasibility and risk assessment. We may request changes.

Timing: GSMA will return comments/ change requests within one week of submission.

- External contractors/suppliers must first be **approved by GSMA**. Any **external contractors/ suppliers** brought in by the client must have appropriate insurance cover.
- **GSMA cannot offer any storage solutions onsite**. All deliveries **MUST** be managed through your staff/ agency.
- **Additional orders** requested through GSMA need to be confirmed in writing by the relevant deadlines or they will be released. A written confirmation will be required as final approval of the total services and related costs together with adherence to our surcharges/cancellation policies and payment confirmation. Deadlines and cancellation terms will be communicated at a later date.
- Additional orders requested through GSMA over and above this contract will be subject to penalties/cancellation fees for any items ordered/cancelled after the given deadlines (see Deadlines and Cancellations for further details).
- Partner will have the opportunity to rehearse any part of their programme with the AV team **two [2] hours** prior to their session (exact timing to be advised by GSMA).
- Additional rehearsal is on a first come first served basis, subject to availability. Exact timing to be advised by GSMA
- If extra rehearsal is required in the room, additional costs will apply, to be covered by the Partner.
- Partner may have the opportunity to walk through their programme's Theatre space prior to the event. Depending on timing, this may not include AV, branding, or programme specific set-ups. Walk through times will take place prior to the start of the Event and timing will be determined by GSMA.
- **The responsibility for running the event lies with the client**. Comprehensive technical schedules should be provided in advance.

FULL DAY PACKAGE

- **Show hours** are from 09:00-17:00h, please contact your GSMA Operations Manager for access time.

MWC[™]
GSMA

上海
2024年6月26 - 28日

Marketing & Registration

Registration

ACCESS TO THE MWC SHANGHAI VENUE

IMPORTANT: All partner programme attendees must hold a MWC Shanghai Pass. (including partner staff, speakers, invited guests, attendees & venue suppliers)

REGISTERING

- All attendees **MUST** register with your own email address
- 'Real name' registration is still a requirement by the local authorities
- Please do not register someone else
- To comply with Government regulations, **we have disabled the bulk registration feature from your Exhibitor and Partner (E&P) account**
- Mainland Chinese Visitors are encouraged to use WeChat to register. Registration account will be linked with your WeChat account. Please do not register for others using your WeChat

MAINLAND CHINESE VISITORS

- **MUST** provide your Chinese ID card details when you register
- Bring the same ID card to the venue to use at the ID Gates
- On scanning the ID card at the ID Gates, the card details will be scanned and biometric technology will make a comparison between the photo on the ID card and a live image taken at the ID gate
- Mainland Chinese visitors who do not bring your Chinese ID card to the venue will be denied entry

NON-MAINLAND CHINESE VISITORS

- **MUST** provide your passport or travel permit details when you register
- Bring the same passport or travel permit to the venue and come to the 'Non-Mainland Chinese Visitors' registration counter
- An ID verification check will take place and a photo taken of the attendee. You will also be provided with a printed badge
- On scanning the badge at the ID gates, biometric technology will make a comparison between the photo taken onsite and a live image taken at the ID gate
- Non-Mainland Chinese visitors who do not bring your passport or travel permit onsite will be denied entry

Registration

REGISTRATION ACCOUNT

REGISTRATION COORDINATOR

You will need to designate someone from your company as the Registration Coordinator. Please provide your Event Programme Manager with the following Coordinator information as soon as possible:

- **Name**
- **Email**
- **Mobile Number**

You may add up to 4 coordinators.

REGISTRATION ACCOUNT

You will be provided a Registration (E&P) Account that will allow you to:

- Input session details, logo and speaker details in the MWC Shanghai website via the Programme Application System (PAS) in the account
- Add additional coordinators
- Customise Invitations
- Distribute passes – **Passes are good for all 3 days of the event**
- Add extended hours to passes you allocate for staff and speakers
- Manage Programmes - Upload attendance list or approve applications via the PAS
- Purchase additional passes or upgrades
- Download final reports

ACCESS TO SESSION

You will need to decide how attendees will be admitted to your session. You may choose to:

Pre-Registered Attendees Have Priority

This is the most popular option. It allows attendees to indicate interest in attending via PAS and allows the partner to build attendance list for the session. Partner will see details of those interested and can do the following:

- Approve: automatically added to attendance list and an email generated to attendee stating they have been approved
- Approve and provide a pass from allocation: automatically added to attendance list and an email generated with instructions on how to register with a pass
- Decline: can decline any attendee and a soft decline email generated informing attendee they do not meet the criteria for the session

We suggest you add the following message to your content to encourage people to indicate their interest in attending:

Pre-registration is encouraged. Attendees who have pre-registered and accepted by (COMPANY NAME) will have preferred seating. All others first-come, first-served as space permits.

By Invitation Only

- Partner will have own attendance list and attendee must be on list to attend. Session will not appear in the Programme Application System (PAS) for attendees to indicate interest in attending. Partner will upload attendance list to their Registration Account, OR
- Partner will allow attendees to pre-register via PAS. Partner will approve. No attendee admitted day of session unless on attendance list

We suggest you add the following message to your agenda content:

PLEASE NOTE: Seating capacity for this session is limited and you must pre-register and be accepted by [COMPANY NAME] to attend. Walk ups will not be permitted the day of the event. If you are accepted, you will receive a confirmation email and added to the approved attendance list.

Allowed to Everyone

- Anyone could attend your session
- Session would not appear for attendees to indicate their interest
- You would not get pre-event attendee data

We suggest you add the following to your agenda content:

Open to all attendees. Pre-registration is not required. All will be seated on a first-come, first-served basis as space permits.

Registration

PROGRAM APPLICATION SYSTEM (PAS)

The Program Application System (PAS) is optional. The system allows people to indicate their interest in attending a session. Leads are fed into your Registration Account and the following options may be taken by you:

- **Accept**
 - Accept and provide one of your passes if they do not have one to attend the event, OR
 - Accept only and add to your attendance list only

- **Decline**

Automated emails are sent to attendee with further details/instructions.

The benefit of using the PAS is all leads are available to you whether you accept or decline. You must adhere to Data Sharing language in your contract with respect to the leads.

There are 2 methods to indicate interest in attending.

METHOD1: Create an Account on MWC Shanghai official website



- Click BUY PASS/ GET YOUR PASS Button
- Provide Demographic Details
- Accepts Terms & Conditions
- Click "Apply for Programmes"
- Select Programmes to Attend
- View application status
- Receive acknowledgement email

METHOD 2: Login to an Existing MWC Shanghai Registration Account



- Select Programmes to Attend
- View application status
- Receive acknowledgement email

ATTENDANCE LIST & SCANNING

ATTENDANCE LIST

- Managed through your Registration account
- Attendees accepted through **PAS** will be automatically added to your attendance list
- "Invitation Only" session - coordinator will need to upload names of those approved
- Approved PAS and Invitation Only attendees will be uploaded to the scanners
- You should have approximately 3 times the number of the capacity of the theatre on your attendance list

ONSITE SCANNING

- Scanners are delivered to the theater the day of your session
- Attendees who scan "green" are on your attendance list will be admitted automatically
- "Red" scan is the indication they have not been approved. Someone from your team will be required to provide instructions for access
- Our scanning staff are instructed to allow access to any "green" scans and hold "red" in the queue line until further instruction is provided by you

Registration

POST EVENT REPORT

POST EVENT REPORT

Data on who attended the session will be **available approximately 2 hours AFTER the session has concluded**. Partners are responsible for downloading their post event report and are responsible for following GDPR Guidelines with respect to data.

POST EVENT DATA

The following information will be a part of the report:

- First Name
- Last Name
- Company name
- Attendee Email Address
- Job Title
- Company Name
- Country / Region
- Continent
- Mobile (Country Code / Number)
- Job Function
- Area of Responsibility
- Company Industry Type / Company main activity
- Areas of Interest (1)
- Areas of Interest (2)
- Areas of Interest (3)

Marketing

MWC SHANGHAI WEBSITE

CONTENT MANAGEMENT

You will be responsible for adding your agenda content, logos, and speakers to the MWC Shanghai website via your registration account. A user guide and video tutorial within your registration account will provide information on how to input your session details.

The **first time** you enter your content you need to send an email to your Event Programme Manager to let them know you have uploaded your information, and they will publish. Once the Event Programme Manager has published, the system will be activated, and you can publish going forward.

LOGO & URL

Logo & url where used:

- MWC Shanghai website
 - Agenda page
 - Sponsors and Partners page
- Email
- Social Media
- Virtual Event Guide on Wechat

You will need to upload logo in the following formats to your dedicated private client folder within our SharePoint document storage.

- JPG or PNG
- High Resolution EPS or AI

MARKETING INCLUSION

EMAIL and SOCIAL MEDIA

Creative: You will be included in the GSMA Email & Social Media plan. GSMA will create the email and social media post on China and ROW channels. There are no dedicated email and social media posts per partner, but rather you will be included as one (1) of several as determined by GSMA.

Schedule: Timing will be determined by GSMA and your Event Programme manager will advise when you are included. There is no action on your part.

VIRTUAL EVENT GUIDE

Creative: You will be included in the MWC Shanghai Virtual Event Guide on WeChat. GSMA will create the event guide. The following may be included but it is subject to the final design layout of the event guide.

- Logo
- Session Title
- Venue
- Event Timing

Schedule: Timing will be determined by GSMA and your Event Programme manager will advise when you are included. There is no action on your part.

PRESS LIST

You may obtain the approved pre-registered press & analyst list attending the event by logging into your MWC Shanghai [Online Event Manual](#) (OEM) account and clicking “Public Relations” on the pull-down menu.

The list will be live from **Tuesday 7 May 2024.**



MARKETING EVENT ASSETS

To help you promote your presence at MWC Shanghai 2024 and get the most from your involvement, we make the event logo and other creative assets available for you. You may use these assets to promote your session.

Click [here](#) to download the **Event Logo and Event Social Assets.**

- **Please Note:** Logos and creative assets are owned by GSMA and are provided for use by GSMA MWC Shanghai attendees, exhibitors, clients, sponsors, official partners and members of the press/analyst community.
- Use by any other party in order to convey an endorsement or relationship is strictly prohibited.
- When possible, please provide backlinks to www.mwcshanghai.com.
- For more information on GSMA Trademarks and logos, view the Terms and Conditions on our Legal page.

Deadlines Marketing & Registration

DELIVERABLE	DUE DATE	NOTES
REGISTRATION COORDINATOR	AS SOON AS POSSIBLE	Please provide the contact information to your GSMA Event Programme Manager
AGENDA DETAILS	AS SOON AS POSSIBLE Uploaded to the website via your dedicated PAS in the registration account	Please make any changes/revisions in the registration account
SESSION TITLE	AS SOON AS POSSIBLE Uploaded to the website via your dedicated PAS in the registration account	No changes to session titles after 31 May 2024
EVENT TIMING	AS SOON AS POSSIBLE Uploaded to the website via your dedicated PAS in the registration account	No changes to event timing after 31 May 2024