

## Raemis™

### More than just a core network

Druid's cellular solutions are built on our Raemis™ technology platform, which is comprised of a 3GPP compliant 4G/5G core, RestAPI and additional functionality.

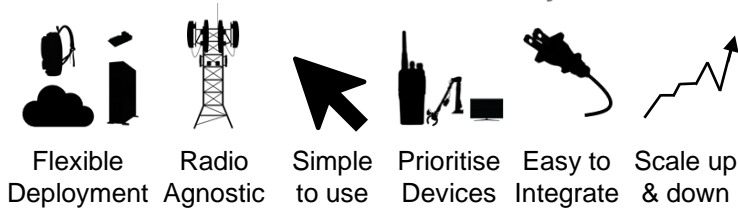

### 3GPP to the Core

Druid's Raemis™ Neutral Host solution is built on our Raemis™ technology platform, which is comprised of a 3GPP compliant Multi-operator Core Network Gateway (MOCN Gateway or MOCN-GW), RestAPI and additional functionality.

### Multiple networks on one radio

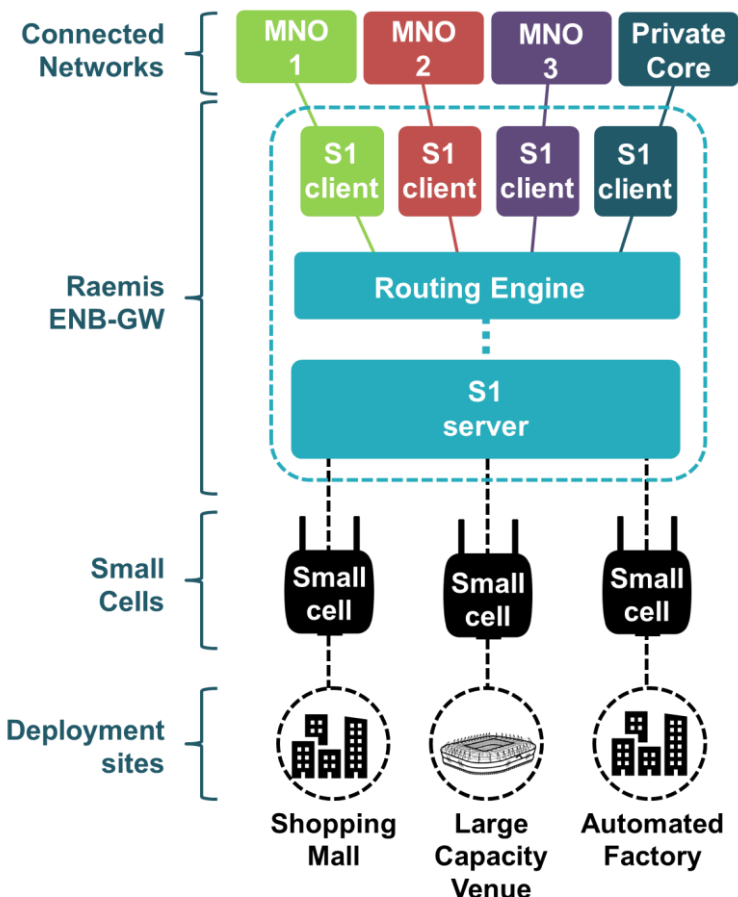

### Raemis™ Neutral Host Main Features

- MOCN-GW Dashboard.
- Easy installation and integration with MNOs.
- 4G and 5G NSA support.
- Security Gateway (SeGW).
- Distributed Network Manager (DNM) integration.
- Performance and scalability (for both scale up and scale down).
- Resilience and redundancy options.
- Real-time System Monitoring.
- Admin User with GUI, Expert Mode and Edit permissions.
- Alarm Monitoring and Troubleshooting.
- Security Hardened images.
- Enterprise Integration.
- Full IPv6 support.

### MNO Integration

Raemis™ Neutral Host can integrate with any MNO using a 3GPP compliant S1 link. The Security Gateway (SeGW) is used to provide secure communication into the MNO's core network. The SeGW also supports CMPv2 if needed.

### Raemis™ Neutral Host 3GPP Features

#### Signaling (S1-C) handling

- Full E911 support
- S1 Flex with Load Balancing.
- Full S1 handover support.
- Ability to route based on TAI or IMSI.
- Support for emergency attaches.
- Access Control of UEs, per eNodeB or per system.
- PWS/CMAS support.

#### Data (S1-U) handling

- TCP MSS Adjust
- IPv4 fragmentation
- IPv6 Packet Too Big

### Druid's Distributed Network Manager

Druid's Distributed Network Manager (DNM) can be used to orchestrate MOCN-GWs. The DNM enables you to deploy many serving gateways, all of which can be managed centrally from one Raemis login.

# MOCN Gateway enables Neutral Host

## MOCN stands for Multi Operator Core Networks

In the Neutral Host scenario, the MOCN-GW enables a single radio to support multiple MNOs. But not just that – it also enables a private network to operate on the same infrastructure, so the deployment will extend MNO coverage for public use, leaving the private network available for non-public use.

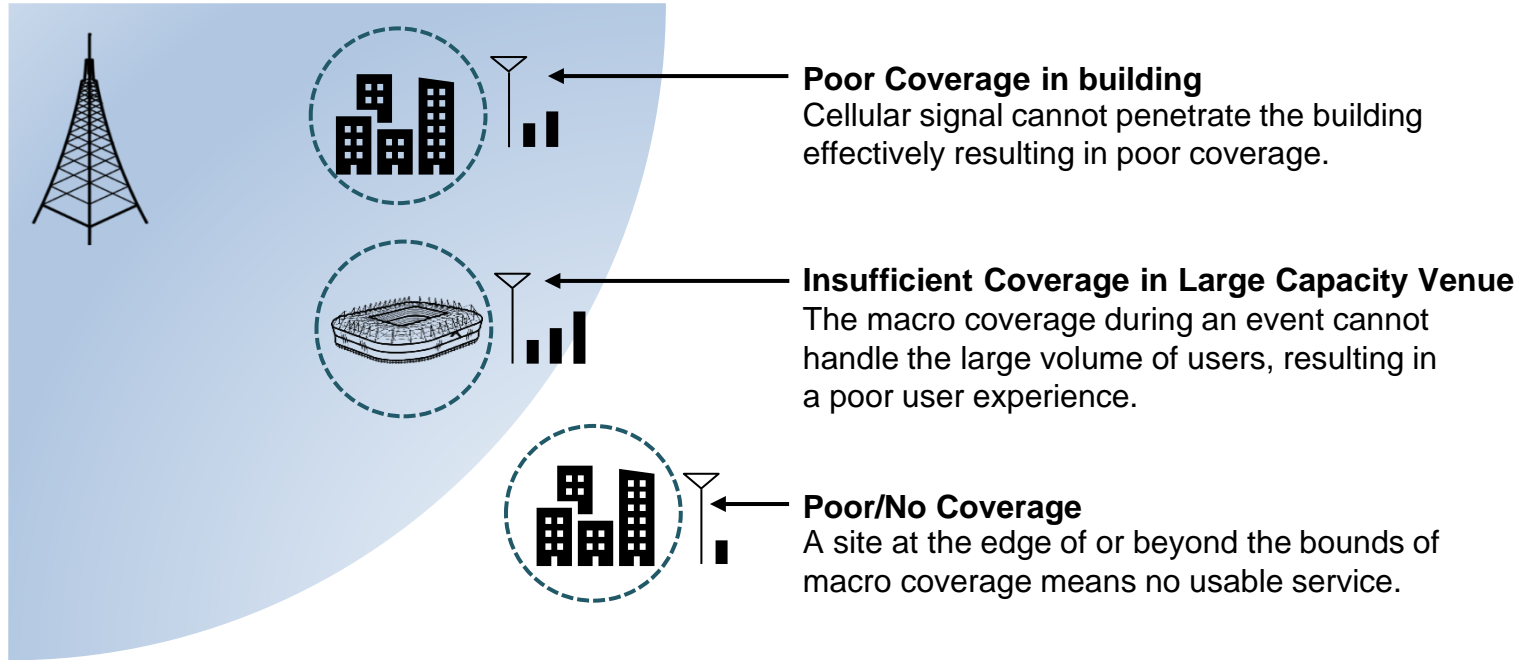

Raemis™ Neutral Host solves the following issues:

- Poor Coverage in building:** Large buildings (e.g. hotels, office blocks, etc.) can have poor indoor coverage due to dense materials blocking MNO signals. Using small cells and Raemis, a building owner can supplement the MNO signals.
- Poor/No Coverage:** At a site that is that is beyond the reach of the MNO infrastructure, coverage is very weak or non-existent. Using small cells and Raemis, a building owner can extend MNO signals to provide service at the site.
- Large Capacity Venue:** Venues with large crowds (e.g. stadiums, festivals, etc.) can have poor service due an overloaded MNO network. Using small cells and Raemis, a building owner can provide extra capacity to the MNO network.

## The Raemis™ GUI

Raemis™ Neutral Host uses the Raemis™ GUI and RestAPI to access the core software and 3GPP components of the network, hiding the complexity of the 3GPP network, enabling an Enterprise's IT manager to perform complex tasks in a few clicks.

The Raemis™ GUI facilitates three levels of customisation:

- White labelling: Replacing the Raemis™ brand logo and product name.
- Extension Apps: Adding a new panel to the GUI.
- New GUI. Replacing the existing GUI with a customer-developed GUI.

## The Raemis™ API

The Raemis™ platform exposes a powerful RESTful API that enables application developers to build on top of Raemis™ or integrate external applications with the Raemis™ platform. Druid developed the Raemis™ PCN GUI using the same RESTful API that is available to application developers. Any feature, data, or action that currently available in the Raemis™ GUI is also available using the RESTful API.

## Scalability

- The Raemis™ platform works for organizations of any size, from small businesses to large enterprises.
- During the commissioning phase, Raemis is configured for the number of operators (1-10), numbers of eNodeB devices (1-1000) and the number of users (1-50,000).
- The Raemis™ platform can scale down to a single eNodeB device and a handful of users all in a single VM that has a small computing and memory footprint.

## gNodeB Gateway

- Druid are currently working on a gNodeB Gateway to enable 5G MOCN deployments, expected to be released in 2024.
- This means that future MOCN deployments will support both a 4G and a 5G capability.